



FULGOR SERVICE
SISTEMI DI AMPLIFICAZIONE

Vertical RAE

16-20

USER AND INSTALLATION GUIDE

PRECAUTIONS USE

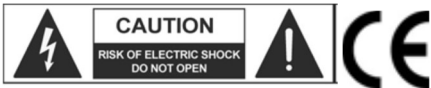

WARNING: To reduce the risk of electric shock, do not remove the cover (or rear panel). Inside, there are no parts that can be repaired by the user; Entrust the repair to qualified personnel.

CAUTION: To reduce the risk of fire or electric shock, do not expose this unit to rain or moisture.



This symbol, when displayed, indicates the presence of a non-insulated hazardous voltage inside the body of the device - sufficient voltage to pose a risk of electric shock.



This symbol, when displayed, indicates important operating and maintenance instructions in the enclosed text. Read the guide.

RECOMMENDATIONS:

All safety and operating instructions must be read before operating the appliance.

Keep the instructions:

Safety and operating instructions must be kept for future reference. This manual is an integral part of the product and must accompany it in case of any change of ownership. This will allow the new owner to know the instructions for installation, operation and safety.

Pay attention:

All warnings on the appliance and operating instructions must be followed accurately. Observe all warnings.

Follow the instructions:

All operating and user instructions must be followed.

Notes preceded by the symbol  contain important safety information: Read them carefully.

DETAILED SAFETY INSTRUCTIONS.

Water and humidity:

The appliance should not be used close to water (eg near baths, kitchen sinks, near pools, etc.).

Ventilation:

The appliance must be placed in such a way that its location does not interfere with the proper ventilation. For example, the appliance should not be placed on a bed, sofa cover, or similar surfaces that can block the ventilation openings or placed in a recessed installation such as a bookcase or cabinet that can prevent the flow of air, Air through the ventilation openings.

Heat:

The appliance must be located away from heat sources such as radiators, thermostats, clothes dryers, or other appliances that produce heat.

Power supply:

- The appliance must only be connected to the type of power described in the operating instructions or on the appliance.



- If the supplied plug does not match the socket, contact an electrician to install an appropriate socket

Grounding or polarization:

- Precautions should be taken to ensure that grounding and polarization of the device are not affected.
- The metal parts of the equipment are connected to ground via the power cord.
- If the power socket does not have a ground connection, contact a qualified electrician to connect the grounding device through the terminal.
- For plastic equipment, periodically check the condition of the power supply.

Power Cord Protection:

The power supply cord must be installed so that it is not to be trampled or pinched by objects placed on or against, paying particular attention to wires and plugs that are wall-mounted.

Cleaning:

- When the unit is to be cleaned, dust can be removed using a compressed air jet or damp cloth.
- Do not clean the unit using solvents such as triethylene, paint thinners, fluids, alcohol, high volatility fluids or other flammable liquids.

Non-use Periods:

The power cord of the appliance must be disconnected from the socket if it is not used for a long time.

Intake of liquids or objects:

Care should be taken to avoid dropping objects and not leaking liquids into the body of the appliance through the grilles.

Safe use of the power line:

- When disconnecting the appliance, hold the plug and the socket securely.
- When the unit is not used for a prolonged period, stop power by pulling the plug out of the power outlet
- To avoid damaging the power supply line, do not pull the power cord and do not use a twisted cable.
- To avoid damaging the power cord of the apparatus, make sure that it is not being trodden or crushed by heavy objects.

Moving the unit:

Before each shift, make sure the drive is off. The power cord must be removed from the socket as well as the unit's connections with other lines.

Do not disassemble the unit:

Do not attempt to disassemble or repair the unit yourself. For any problem that cannot be resolved with the help of this manual, contact a qualified technician or contact our company www.fulgorservice.it

Malfunctions:

For any malfunctions contact our company (www.fulgorservice.it).

IMPORTANT SAFETY RULES:

Install by following the instructions.

- Never open the equipment: inside there are no user-serviceable parts.
- If you notice a strange smell coming from the appliance, turn it off immediately and disconnect the power cord.
- Do not obstruct the ventilation grilles of the appliance.
- Avoid working overloading the unit for extended periods of time.
- Do not force commands (buttons, controls, etc.)



- For safety reasons, do not unscrew the plug-in connection. The ground connection is necessary to safeguard operator safety
- Use only the connectors and accessories specified by the manufacturer.

The equipment must be kept away from:

- Damp places
- Direct exposure to heat sources (such as sunlight).
- Unsuitable ventilation

In the presence of lightning storms or when the apparatus is not in use, unplug the power plug from the socket.

To prevent the risk of fire and electric shock, keep the equipment away from splashes and drops. Above the apparatus should not be placed vases or other objects containing liquids.

FULGOR SERVICE s.n.c. Disclaims any liability for incorrect installation of the unit.

GUARANTEES AND RETURN:

The product is equipped with a guarantee of operation and compliance with its specifications, as stated by the manufacturer. The warranty is 24 months from the date of purchase. Faults detected within the warranty period, attributable to defective materials or construction defects, must be promptly reported to your dealer or distributor, enclosing the purchase date documentation and the description of the defect type found. Failures caused by improper use or tampering are excluded from the warranty. Fulgor Service s.n.c. Establishes by means of return verification the declared defect, related to proper use, and the effective validity of the guarantee; It then provides for the replacement or repair of the products, but does not however oblige any compensation for direct or indirect damages resulting from the defect.



MAIN FEATURES AND PERFORMANCES

	RAE 16	RAE 20
INTERNAL IMPEDANCE	8Ω	6Ω4
MAXIMUM ARRAY POWER	240W	300W
CONTINUOUS ARRAY POWER	120W	150W
FREQUENCY RESPONSE	50-16000Hz	50-16000Hz
HORIZONTAL DISPERSION @ 20m	180°	180°
VERTICAL DISPERSION @ 20m	500Hz 20° 1000Hz 10° 2000Hz 5° 4000Hz 5°	500Hz 20° 1000Hz 10° 2000Hz 5° 4000Hz 5°
SENSITIVITY @ 1m (2,83Vrms)	104dB SPL	106dB SPL
DIMENSIONS	L 104mm H 1531 m D 78mm	L 104mm H 1900mm D 78mm
WEIGHT	10,6Kg	13Kg
MOUNTING SYSTEM	4x90° BRACKETS	4x90° BRACKETS
STANDARD COLOURS	WHITE (RAL 9010) VOLCANO (RAL 7006)	WHITE (RAL 9010) VOLCANO (RAL 7006)
INPUT CONNECTOR EUROBLOCK 5,08	6 POLE	6 POLE



HORIZONTAL DISPERSION

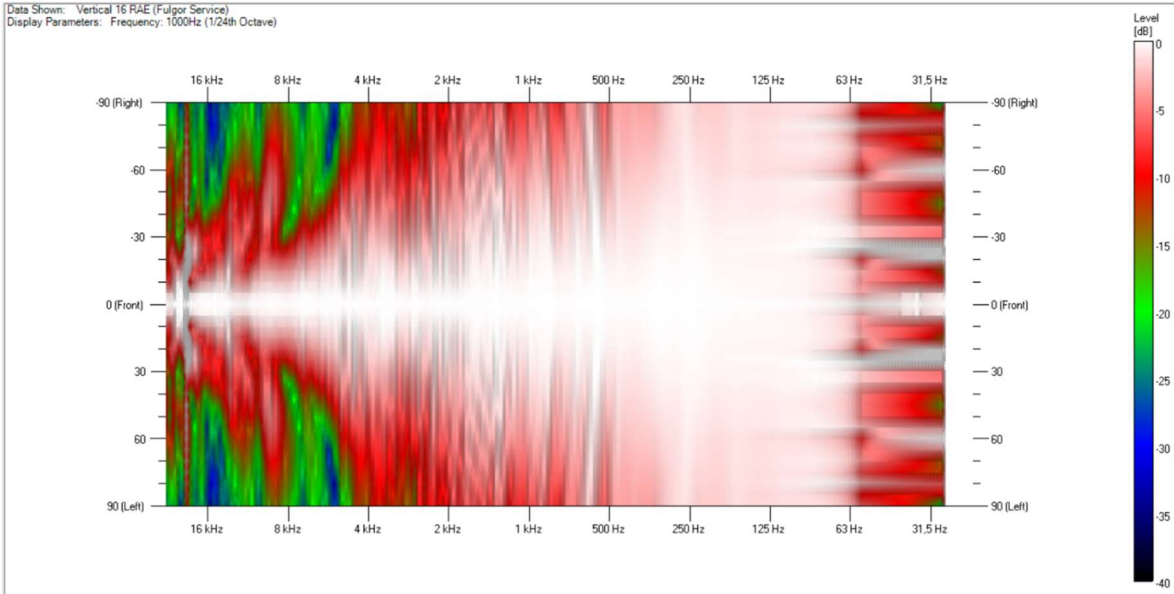

V-16

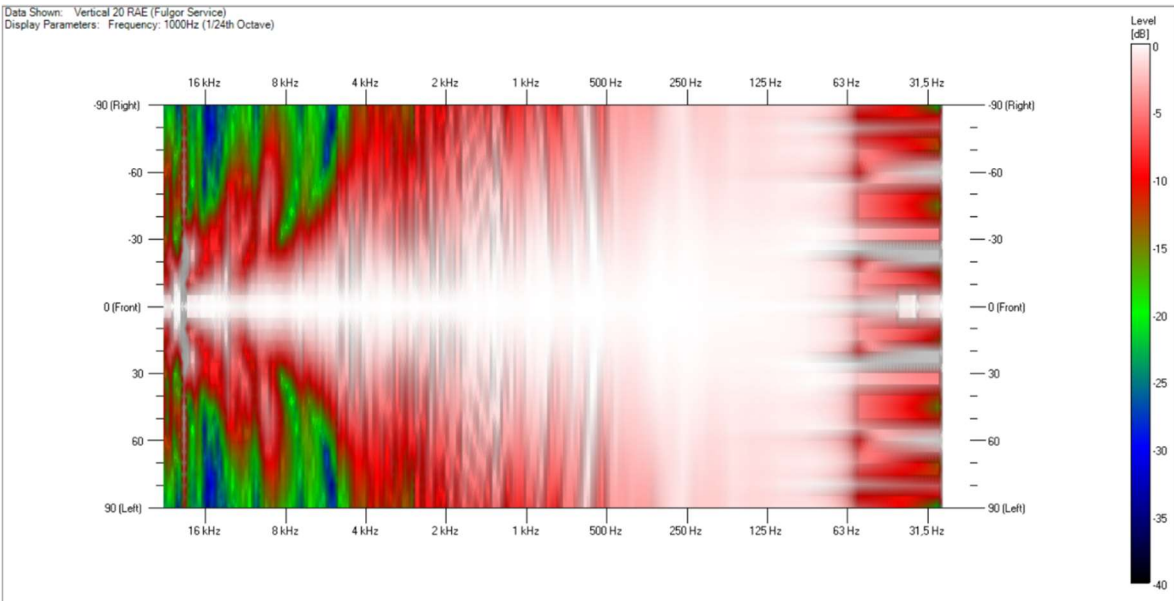

V-20



VERTICAL DISPERSION

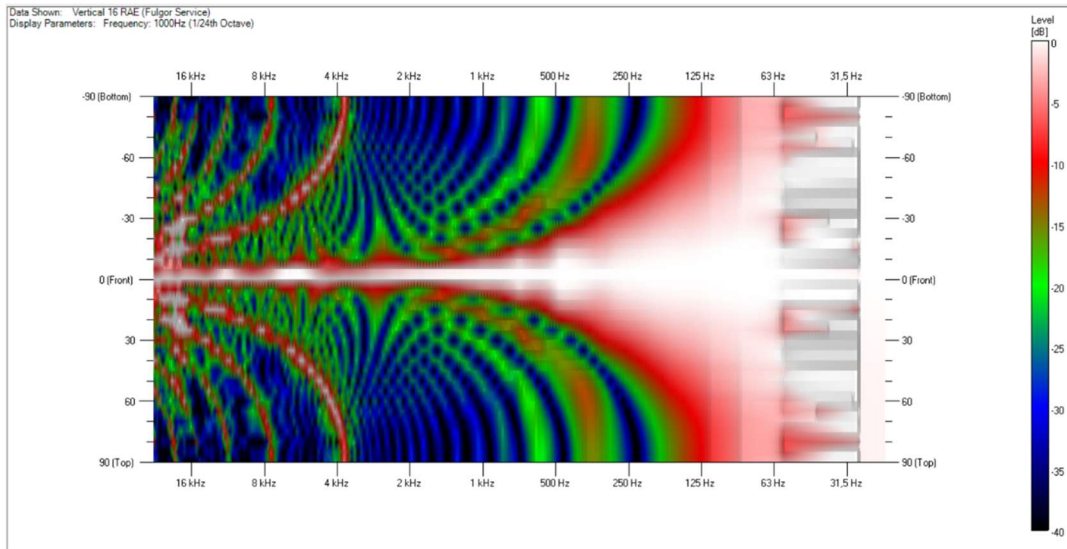

V-16

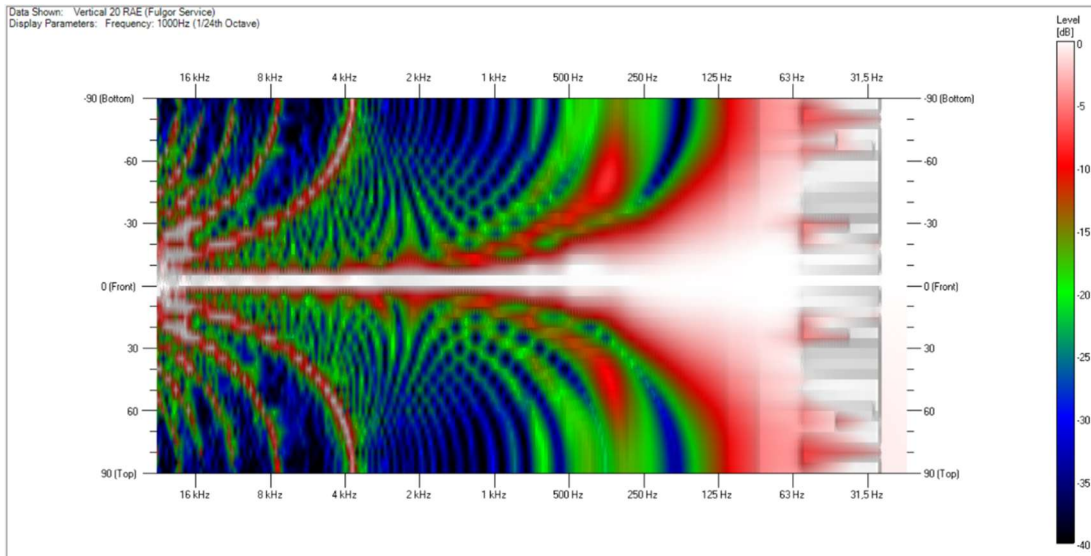

V-20



FREQUENCY RESPONSE BALOON AND SPL

Data Shown: Vertical 16 RAE (Fulgor Service)
Display Parameters: Frequency: 2500Hz (1/24th Octave)

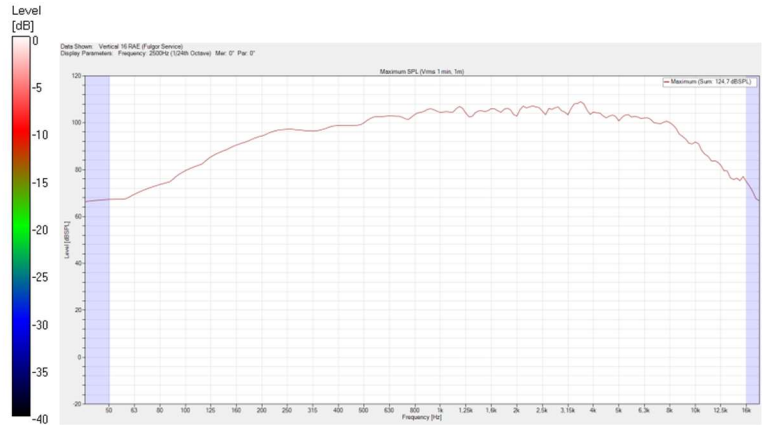
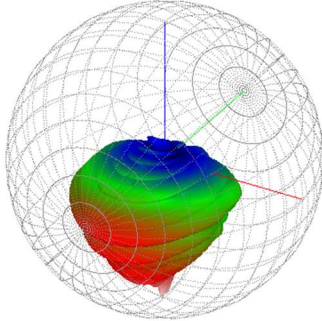

V-16

Data Shown: Vertical 20 RAE (Fulgor Service)
Display Parameters: Frequency: 2500Hz (1/24th Octave)

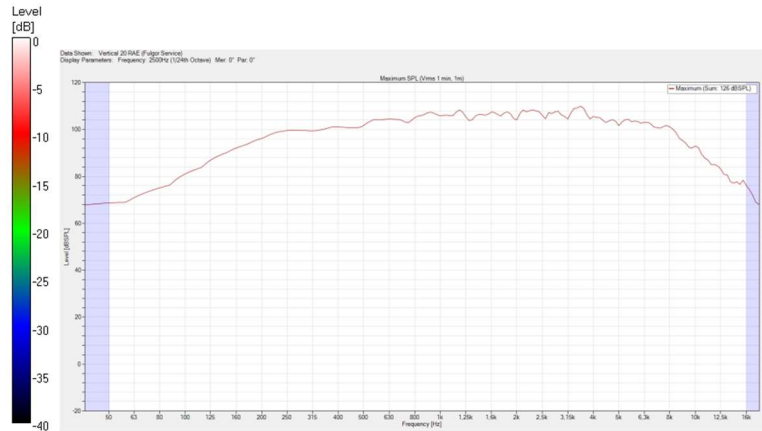
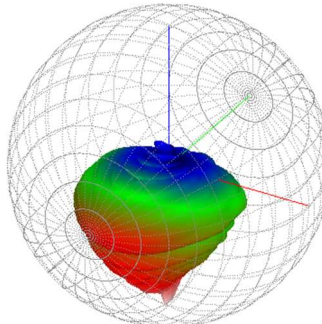

V-20



INSTALLATION

V-16



1530mm

V-20



1900mm

PHYSICAL DIMENSION

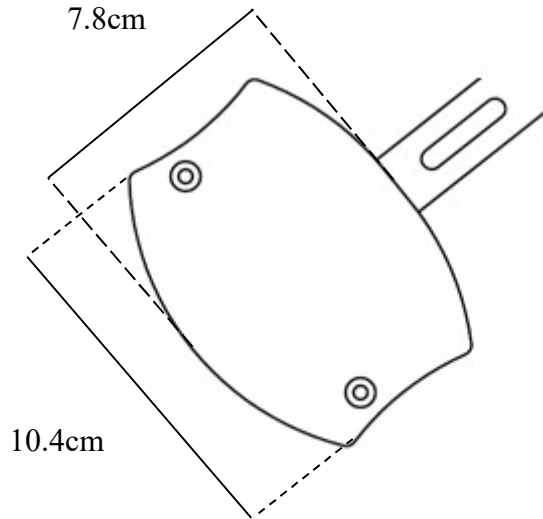

MODEL	HEIGHT	WIDTH	DEPTH
RAE 16	1531mm	104mm	78mm
RAE 20	1900mm	104mm	78mm

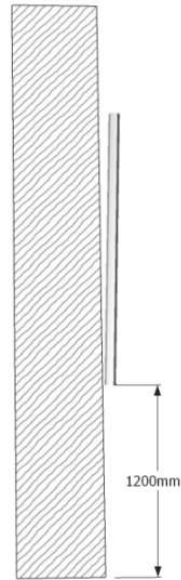

INSTALLATION INDICATIVE HEIGHT

V-16**V-20**

POSSIBLE BRACKETS' COMBINATIONS

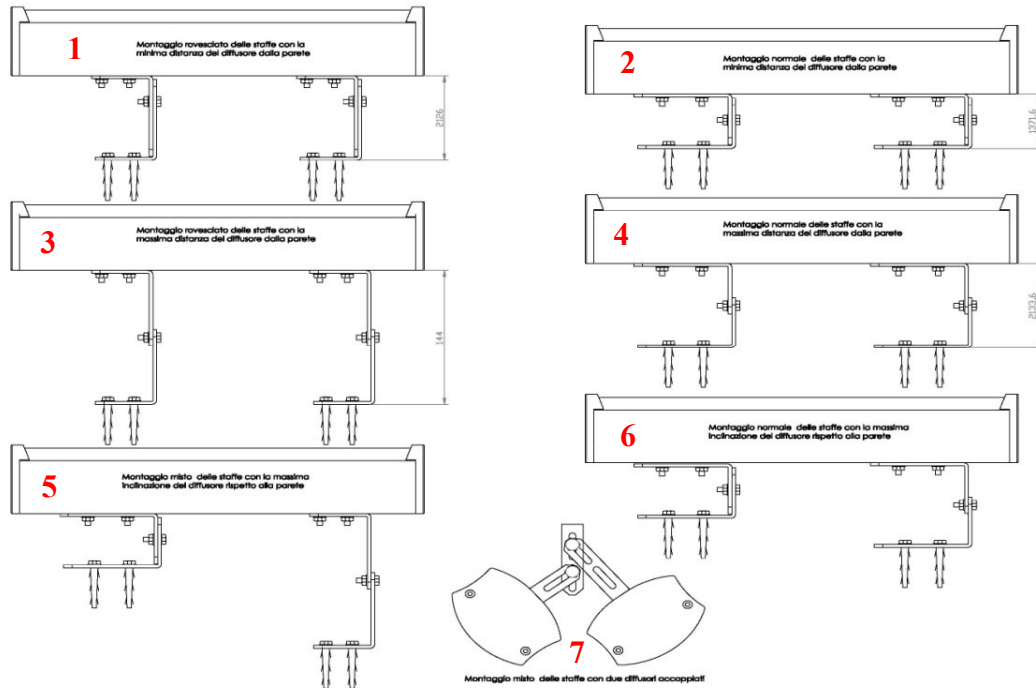

For installation, various options are available, based on need, to optimize the SPEAKER/WALL distance.

- 1.** Brackets inverted mounting with the minimum distance of the speaker from the wall.
- 2.** Brackets normal mounting with the minimum distance of the speaker from the wall.
- 3.** Brackets inverted mounting with the maximum distance of the speaker from the wall.
- 4.** Brackets normal mounting with the maximum distance of the speaker from the wall.
- 5.** Brackets mixed mounting with the maximum inclination of the speaker with respect to the wall.
- 6.** Brackets normal mounting with the maximum inclination of the speaker with respect to the wall.
- 7.** Brackets mixed mounting with two speakers coupled.

WARRANTY CERTIFICATE

Dear Customer,

we are pleased to inform you that it has been transposed into Italian law, through Legislative Decree no. 24 of 2 February 2002, a Community directive on sales and consumer protection.

This Directive makes a distinction between consumer goods for private use and those used exclusively in the professional field.

In particular, the new standard applies only to consumer goods for private use, and consequently consumer goods used in the course of their professional or business activities will be guaranteed according to the normal general sales rules provided by the civil code.

In both cases, FULGOR SERVICE, by virtue of the quality of its products, applies a 24 months warranty period.

Warranty management

As Directive 1999/44 / EC represents a high level of consumer protection, the decree governs certain aspects of sales contracts concluded between **the consumer and the seller** and guarantees relating to the consumer goods sold.

For the purpose of the Legislative Decree, it is understood that:

For Consumers any natural person who purchases consumer goods for use solely in the private sector and hence outside his or her professional or business activity;

For Seller, any natural or legal person, whether public or private, who uses one of the above-mentioned contracts in the course of his or her business or professional activity;

For the sake of consumption any mobile goods, with express exclusion of the forced sale of goods; Water and gas, when not packaged for sale in a volumetric volume or in a specified quantity.

Consumers are entitled to rights under applicable national legislation governing the sale of consumer goods. The warranty does not affect these rights.

The warranty is valid in all EU Member States.

According to the new legislation, any claim by the consumer to the warranty must be submitted to the retailer and / or point of sale at which the product was purchased.

FULGOR SERVICE has also set up a toll-free number 800-804067. By calling this number we will be able to collect your reports regarding warranty issues and possibly arrange direct return / repair methods.

The number is active from Monday to Friday (excluding holidays), from 8am to 12.30pm and from 14am to 5pm in the winter months and from 7.30am to 12.30pm during the summer months (July and August).

GUARANTEE CLAUSES

The product is guaranteed for a period of 24 (twenty-four) months from the date of purchase. Warranty means repairing or replacing equipment that is defective in the sales contract (and generally product information), the warranty is free of charge and excludes shipping costs for the Consumer.

The warranty is valid only if this warranty certificate, completed in all its parts by the buyer and accompanied by a valid proof of purchase (copy of the invoice or tax receipt for the consumer), is presented at the moment of the request for intervention. The non-compliant product must be returned to the original packaging, complete with all accessories.

The serial number on the product must not be erased or made unreadable, since the warranty is invalid.

The warranty does not apply in the case of damage caused by improper use, use or installation that does not comply with the instructions given, tampering, product or serial numbering, accidental or negligent damage to the buyer with particular reference to the outside parts. It also does not apply in case of faults due to connections of the device at voltages other than those indicated or sudden changes in the mains voltage to which the appliance is connected, as well as in case of faults caused by liquid infiltration, fire, discharges Inductive / electrostatic or discharge caused by lightning, overvoltages or other phenomena outside the device.

Warranty includes parts subject to wear after use, batteries when supplied, connectors and connectors, connectors, external parts and plastic supports, which do not have manufacturing defects.

They are excluded from the warranty: periodic checks, software updates, settings, maintenance.



After the warranty period has expired, the assistance will be charged by charging the replaced parts, labor and transport costs, according to the rates in force.

The guarantee is provided by: FULGOR SERVICE snc., Via Caduti del lavoro 58, 19021 Arcola - La Spezia.

CONSUMER DATA

Fill in every part and join the product. In the case of warranty, please always enclose a copy of the valid **proof of purchase** and send the product to the following address: FULGOR SERVICE snc., Via Caduti del lavoro 58, 19021 Arcola La Spezia or fax 0039 0187 952326.

Surname _____ Name _____		
Parish/Religious Istitute/other _____		
Street _____		
Zip code _____	City _____	Prov. _____
Tax code/VAT _____		

PRODUCT DATA

MODELO _____	SERIAL NUMBER _____
DATE OF PURCHASE __ / __ / __	N. INVOICE _____ RESELLER _____



Information pursuant to Legislative Decree no. 196 of 2003 ("Personal Data Protection Code")**Dear Customer,**

We inform you that FULGOR SERVICE, pursuant to art. 13 of Legislative Decree 196/2003, will process your data provided by you in compliance with the legislation on the protection of the processing of personal data. The disclosure of the data is optional but any refusal to provide them will result in the impossibility of performing the obligations arising out of the repair service of which you are a party (Article 13, paragraph 1, letter C, Legislative Decree 196 of 2003). The personal data you provide is collected by electronic means and processed, including by means of electronic means, directly and / or through delegated third parties (repair and delivery company) for the following purposes:

- purposes related to the execution of the service and the management of the repair and return of the products sent for repair.

In any case, your data will not be disclosed (if not to a repair or redemption company) or sold to third parties. Within FULGOR SERVICE the data can only be acquired by persons specifically assigned to the Information Systems, Administration and Accounting, Customer Service departments.

According to art. 7 of Legislative Decree 196/2003 You have the right, at any time, to obtain from the Data Manager the information on the processing of your data, the manner and purpose and the logic applied to it.

The Data Controller is the legal representative of FULGOR SERVICE snc., Via Caduti del lavoro 58, 19021 Arcola - La Spezia. www.fulgorservice.it

Date _____

signature _____

Stamp and signature of the reseller



The symbol of a jar of a trash trimmed by a cross indicates that the product should not be disposed of with other household waste at the end of the life cycle, but be collected separately. In order to avoid any damage to the environment and human health due to the presence of hazardous substances, you are encouraged to give such waste to the distributor / retailer when purchasing a new product or by handing over to designated collection centers by local authorities. Penalties are provided for abusive disposal of these products.

